

CL0116 Solar LED Lamp Controller

GENERAL DESCRIPTION

CL0116 is a solar LED lamp controller with one battery, in which solar-charging and LED-driving sections are included: the former can help to detect voltage on the solar cell, control the charging process and prevent the reversely charging from battery to solar cell etc; the later has the functions of detecting status of battery, producing 100KHz pulse-train, being in standby mode manually and limiting the peak driving current etc. Only an external inductor is needed to construct a booster-type switching power supply with over 90% of charging efficiency and driving efficiency. CL0116 has the advantages of high efficiency, low power dissipation, low minimum operating voltage 0.8V and realizing the charging and LED-driving functions automatically etc.

FEATURES

- Only an external inductor
- Operating range is 0.8V~3.0V
- Driving current is 10mA~100mA
- Maximum driving efficiency is 90 %
- Package TO94

ABSOLUTE MAXIMUM RATINGS

SYMBOL	ITEMS	VALUE	UNIT
V_{MAX}	Maximum voltage of each pin	5	V
I_{MAX}	LX maximum current	0.8	A
T_{OPR}	Operation Junction Temperature Range	-40~+125	°C
T_{STG}	Storage Temperature	-60~+150	°C
V_{ESD}	ESD Susceptibility	2000	V

TYPICAL APPLICATIONS

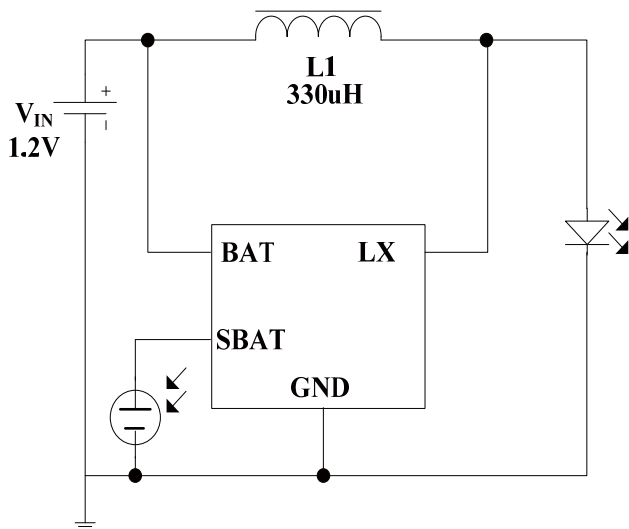

PIN ASSIGNMENT

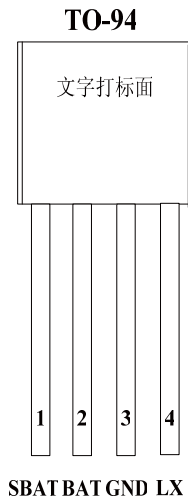

PIN DESCRIPTIONS

PIN NO.	PIN NAMES	DESCRIPTION
1	SBAT	the positive terminal of solar cell
2	BAT	Supply voltage terminal
3	GND	Ground
4	LX	Output terminal

ELECTRICAL CHARACTERISTICS

Symbol	Parameter	Min.	Typ.	Max.	Unit
VDD	Input voltage	0.8		3.0	V
Vsld_th	Turn-on threshold	120	135	150	mV
Vsld_hys	Turn-on threshold hysteresis		300		mV
Fosc	Switching Frequency		100		KHz